

I. REMOVING THE OLD POWERHEAD (METAL TOP CHANNEL)

1. Unplug unit and open the air cleaner to the exposed electrode (Figure "A").
2. Using a pair of pliers, straighten the electrode (Figure "B").

FIGURE "A"

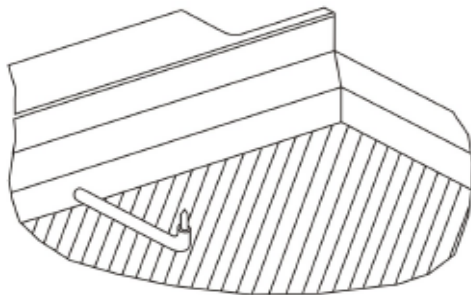
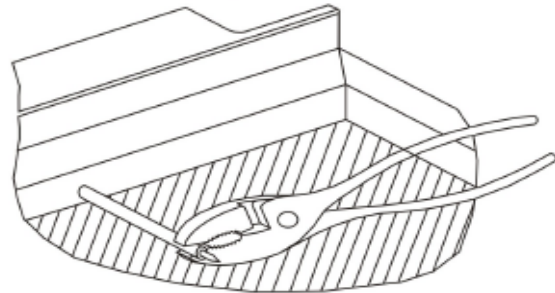

FIGURE "B"



3. With a screwdriver, remove the two screws that hold the metal powerhead housing in place (Figure "C").
4. Pull up on the metal powerhead housing while pushing up on the electrode (Figure "D").

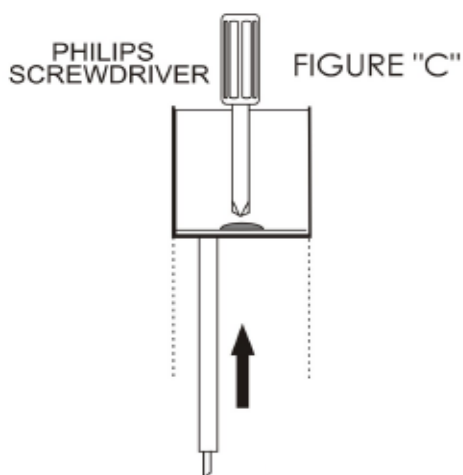
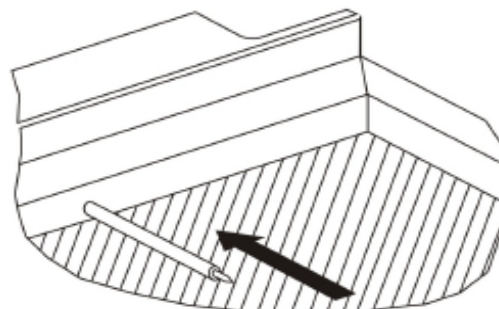
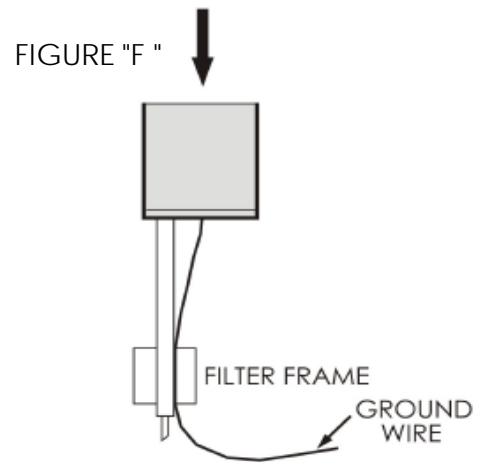
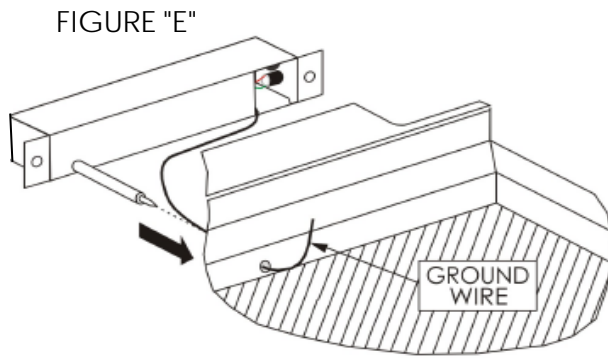

FIGURE "D"



II. INSTALLING THE NEW POWERHEAD

1. Insert the ground wire through the hole on the channel and frame (Figure "E").
2. Insert the electrode through the hole in the channel and frame (Figure "F").



3. Cut the ground wire so that it protrudes just inside the frame (Figure "G").
4. Using pliers, carefully bend the tip of the electrode and the plastic sleeve up 90 degrees (Figures "H" and "I" and "J") so that the electrode seats in the plastic insulator button when the air cleaner screens are closed. Replace the two screws securing the metal powerhead housing to the top channel.

FIGURE "G"

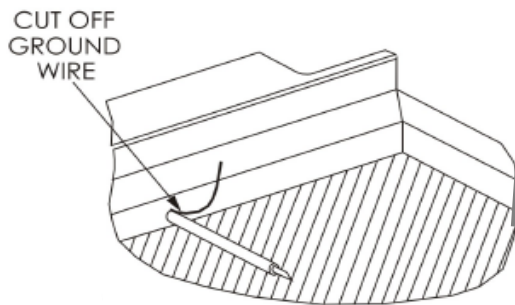

FIGURE "H"

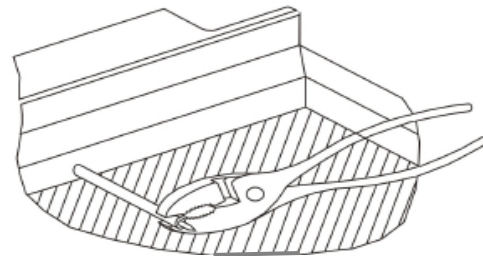

FIGURE "I"

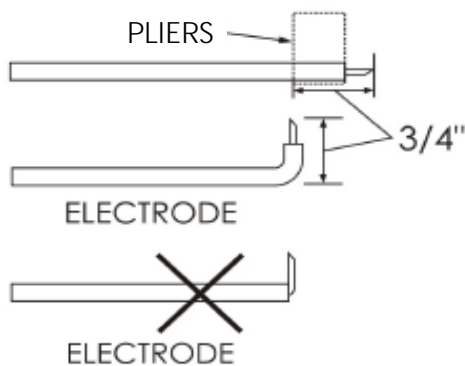
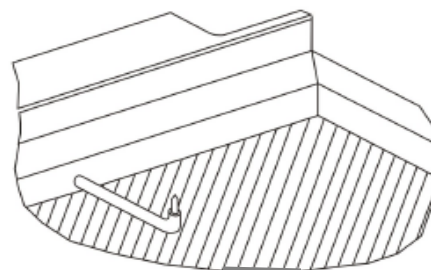

FIGURE "J "



5. Replace the media pad and close the air cleaner. When plugged in and power is "on", the indicator light should be illuminated.